

## Intro

The current relay JGA2011 is a universal control unit for sensing 2 4 ... 20 mA signals to 2 relay outputs.



## Liability and warranty

Every JGA2011 is checked before sending for correct operation. Therefore Boutronic has a warranty period of 1 year.

The warranty expires if:

- The defect is caused by gross negligence or by improper installation
- Repairs and/or modifications to the JGA2011 without permission from Boutronic.

Boutronic is in no way liable for damage caused as a direct or indirect consequence by the use of the JGA2011.

**Menu**

- Intro ..... 1**
- Liability and warranty ..... 1**
- Menu..... 2**
- Connections..... 3**
  - Connection example ..... 4
  - Operation ..... 4
  - Current inputs..... 4
  - Potentiometer ..... 5
  - Relay ..... 5
  - Switching delay Relay ..... 5
- Change settings ..... 6**
- Potentiometer ..... 6**
- DIP-switches ..... 6**
- Setting with the serial menu ..... 6**
  - Relay 1 ..... 7
  - Relay 2 ..... 7
  - Debug level..... 7
  - Factory defaults..... 7
  - Factory test ..... 7
- Technical specifications..... 8**
  - General ..... 8
  - Power ..... 8
  - Inputs ..... 8
    - Current input..... 8
  - Outputs ..... 8
    - Relay..... 8
- Measurements ..... 9**

## Connections

The figure below shows schematically the JGA2011:

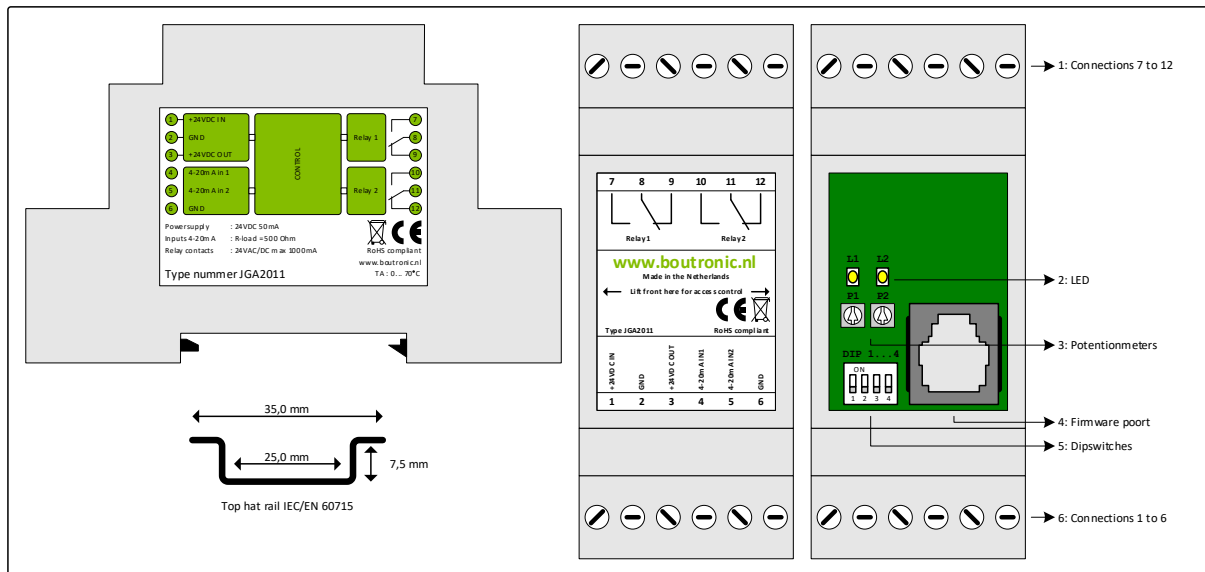

Nr	Unit	Description
1	Connection 7 ... 12	Connection 7 ... 12, see front for type of connections
3	LED	These LEDs indicate whether the value of the corresponding input is above or below the switching threshold. The burning time of the LED corresponds to the set delay (default 1 sec). After this time, the relay switches.
2	Potentiometer	Potentiometer for setting the switching threshold of the relays P1: Relay 1 P2: Relay 2 When DIP-switch 3 is ON, a software delay is used.
4	Firmware port	Connection to PCB (with a Boutronic dongle) for firmware update or programming settings
5	DIP-switches	DIP-switch 1: reserved DIP-switch 2: reserved DIP-switch 3: Time with potentiometer or software DIP-switch 4: reserved See chapter <b>change settings</b>
6	Connection 1 ... 6	Connection 1 ... 6, see front for type of connections

### Connection example

A connection example is given in the image below.

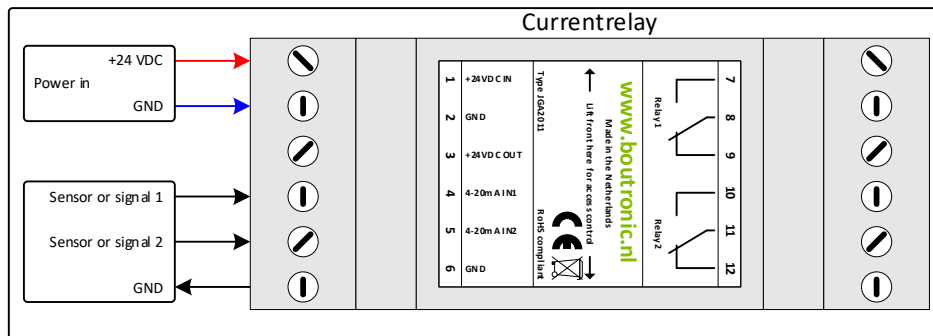

### Operation

The image below simply shows how the JGA2011 works.

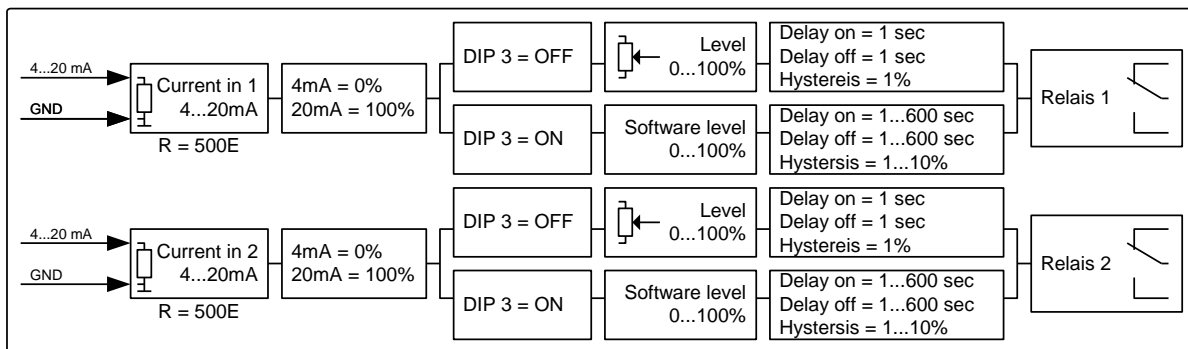

### Current inputs

A signal of 4... 20 mA is applied to the current inputs. This signal is read in and converted to a 0% to ... 100% value.

If the current input is lower or equal than 4 mA, the JGA2011 will convert the value to 0%, if the current input is higher or equal than 20 mA, the JGA2011 will convert the value to 100%.

Note: The maximum current that may be offered is: 30 mA.

### Potentiometer

The signal from the potentiometer is read in and converted to a 0 ... 100% value. If DIP-switch 3 is OFF, this value is compared with the value of the current input. If the current input value is higher than the set value (switching threshold), the relay will be switched on. If the current input value is lower than the set value, the Relay will be disabled.

Example: If the current input measures a signal of 12 mA, this current is converted to a value of 50%. When the potentiometer is set to 40%, the relay will switch on. When the potentiometer is set to 60%, the relay remains switched off.

When DIP-switch 3 is ON, the set values are used as levels.

If the potentiometer is turned all the way to the left, the switching threshold is minimal. If the potentiometer is turned all the way to the right, the switching threshold is maximum.

### Relay

The relay switches when the corresponding input exceeds the switching threshold. Input 1 switches relay 1 and input 2 switches relay 2.

### Switching delay Relay

The switching delay with which the relay is switched with respect to the input is set to 1 second by default. If DIP-switch 3 is ON, this time can be set *for each relay separately*. This time can only be set *through* the USB port of the PC in combination with the Boutronic USB dongle

The operation of the switching threshold and the switching delay is schematically shown in the figure Below:

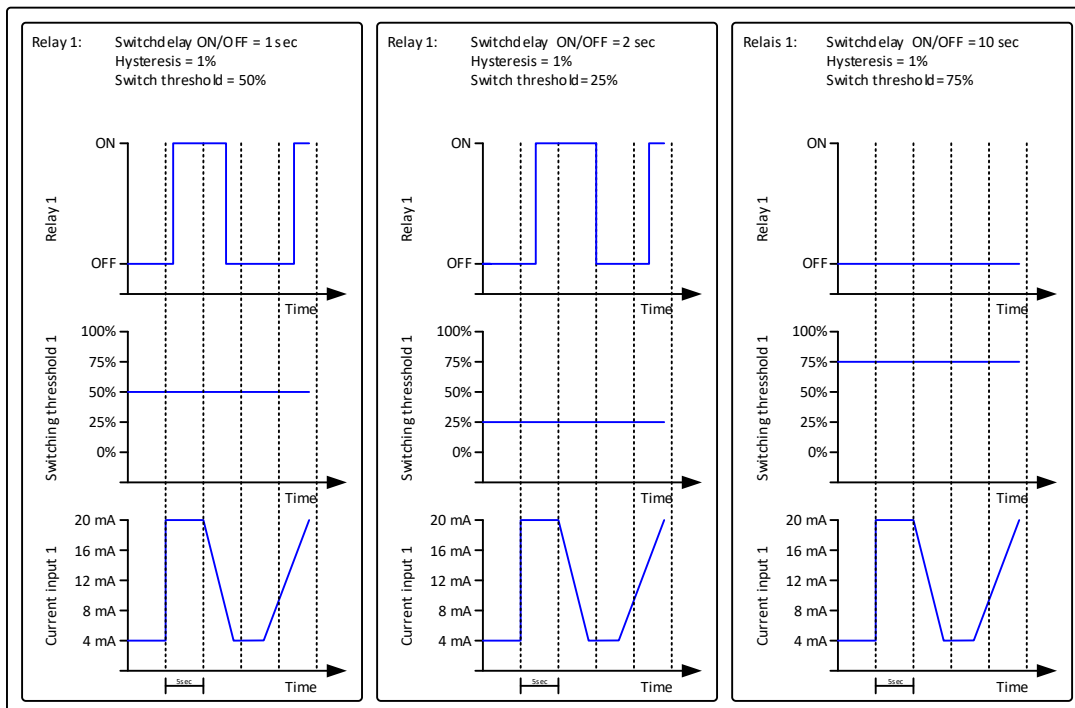

## Change settings

The settings of the JGA2011 can be changed in two ways:

With the potentiometer, the DIP-switches and the programming button or with the USB port of the PC in combination with the Boutronic USB dongle.

## Potentiometer

The switching threshold of the relay is set with the potentiometer. Each relay has its own potentiometer. When DIP-switch 3 is OFF, the setting through the potentiometer is active.

## DIP-switches

A 4-fold DIP-switch is available on the JGA2011. The following functions can be enabled or disabled by means of the DIP-switches:

DIP	Off	On
1	Reserved	Reserved
2	Reserved	Reserved
3	Use potentiometer for threshold level. Delay is fixed 1 seconds and the hysteresis is fixed 1%	Use software settings for threshold level, Delay and hysteresis
4	Reserved	Reserved

## Setting with the serial menu

You can change the settings with the USB port and the Boutronic Studio. The Boutronic Studio can be downloaded from our website:

[www.boutronic.nl/producten/boutronic\\_studio\\_instellen\\_via\\_windows](http://www.boutronic.nl/producten/boutronic_studio_instellen_via_windows)

To connect the JGA2011 to the PC follow the next steps:

1. Connect the JGA2011 to your PC by a Boutronic USB dongle
2. Open the Boutronic Studio 2 with the tab 'Terminal', set the baud rate to 9600 and connect
3. Click on the black screen with the mouse and press three times the + (+++)

The following text is given on the screen:

--- MENU ---

1. Relay 1
2. Relay 2
- D. Debuglevel
9. Factory defaults
- T. Factory test

With the '1, 2, D, 9 and T' the option will be selected

With the '+' key the output level will be increased

With the '-' key the output level will be decreased

With the 'enter' key the value will be stored.

With the 'esc' key the programming will be stopped.

With the '9' key you will set all setting to factory levels

**Relay 1**

Menu for changing setting relay 1

Value	Description	range	Factory settings
Level: x %	Switching level when the relay is switching	0 ... 100 %	50 %
Hysteresis: x %	Hysteresis in %	1 ... 10 %	1 %
Delay on: x sec	Switching delay on	0 ... 600 sec	1 sec
Delay off: x sec	Switching delay off	0 ... 600 sec	1 sec

**Relay 2**

Menu for changing setting relay 2

Value	Description	range	Factory settings
Level: x %	Switching level when the relay is switching	0 ... 100 %	50 %
Hysteresis: x %	Hysteresis in %	1 ... 10 %	1 %
Delay on: x sec	Switching delay on	0 ... 600 sec	1 sec
Delay off: x sec	Switching delay off	0 ... 600 sec	1 sec

**Debug level**

This option is for factory use only.

**Factory defaults**

This option can set all programming values to factory values.

Value	Description
N. No	No values will be set to factory values
Y. Yes	All values will be set to factory values

**Factory test**

This option is for factory test only.

## Technical specifications

### General

Description	Value	Unit	Remarks
Measurement	90 x 36 x 57	mm	L x B x H
Mounting	DIN-rail (Top hat rail)		IEC/EN 60715
Material	Plastic ABS		
Weight	80	gram	
Temperature storage	-20 ... +60	°C	
Temperature operational	0 ... +70	°C	
Relative humidity	10 ~ 95% RH @ 40°C, non-condensing		
Protecting range	IP20		

### Power

Description	Min	Typ.	Max	Unit	Remarks
Power in	20	24	30	VDC	
	20	24	24	VAC	1
	-	35	-	mA	
Power out	20	-	30	VDC	2
	-	-	150	mA	3

1. Note: one of the phases is directly connected to the GND
2. This voltage is equal to the power supply in (single-sided rectified and with capacitor buffered)
3. With a resettable fuse

### Inputs

#### Current input

Description	Min	Typ.	Max	Unit	Remarks
Input voltage	-	-	30	VDC	
Input current	4	-	20	mA	Max 30 mA
Input impedance		500		Ω	

### Outputs

#### Relay

	Min	Typ.	Max	Eenheid	Opmerkingen
Switching voltage	-	-	30	VDC	
Contact current	1	-	500	mA	
Contact impedance	0,1	-	-	Ω	
Separation	-	-	500	VDC	Galvanic



### Measurements

